

Operating instrucciones Peristaltic Pumps

DSM Series

www.boyser.com

1. Introduction

This instruction manual must accompany the pump at all times for as long as it is in use. The DSM series peristaltic pump is a machine for fluid handling intended to be used in industrial areas, as such the instruction manual is part of the legislative provisions for the safe and correct use of the pump.

This instruction manual does not substitute any installation standard or any additional future standard.

1.1. How to use this manual

This manual is intended as a reference book by means of which qualified users are able to install, commission and maintain the peristaltic pumps mentioned on the front cover.

1.2. Original instructions

The original instructions for this manual have been written in English. Other language versions of this manual are a translation of the original instructions.

1.3. Other supplied documentation

Documentation of components such as motors and inverters is normally not included in this manual. However, if additional documentation is supplied, you must follow the instructions in this additional documentation.

1.4. Service and support

For information with respect to specific adjustments, installation, maintenance or repair jobs which fall beyond the scope of this manual, contact BOYSER. Make sure you have the serial number peristaltic pump at hand.

1.5. Environment and disposal of waste

Enquire within your local government about the possibilities for reuse or environment friendly processing of packaging materials, (contaminated) lubricant



CAUTION

Always observe the local rules and regulations with respect to processing (non reusable) parts of the hose pump.

2. Safety

2.1. Explanation of the safety information



This symbol identifies the instructions of this manual, which must be observed to avoid failure to meet safety standards.



This symbol identifies the instructions of this manual, which must be observed to avoid compromising electrical safety.



This symbol identifies the instructions of this manual, which must be observed to guarantee the correct operation of the pump.

Other documentation supplied: instructions in all additional documentation supplied with the pump must also be followed (instructions for components such as gearbox, motor, sensor, frequency controller).

2.2. Intended use

The peristaltic pump is exclusively designed for pumping suitable products. Every other or further use is not in conformance with the intended use. In case of doubt, it is the use which appears to be its intended use judging from the construction, execution and function of the product. Observing the instructions in the user's documentation also belongs to intended use.

Only use the pump in conformance with the intended use described above. The manufacturer cannot be held responsible for damage or harm resulting from use that is not in conformance with the intended use. If you want to change the application of your peristaltic pump, contact BOYSER.

2.3. Responsibility

The manufacturer does not accept any responsibility for damage or harm caused by not (strictly) observing the safety regulations and instructions in this manual and the also supplied documentation, or by negligence during installation, use, maintenance and repair of the peristaltic pumps mentioned on the front cover. Depending on the specific working conditions or accessories used, additional safety instructions can be required.

2.4. User qualifications

Pumps are machines that can present dangers due to moving parts and the presence of a pressurised fluid within the tube.

THE FOLLOWING CAN CAUSE SERIOUS DAMAGE AND INJURY:

- Improper use
- Removal of the protections and/or disconnection of protective devices
- Lack of inspections and maintenance

The person responsible for safety should therefore guarantee that the pump is transported, installed, put in service, used, maintained and repaired by qualified personnel who should possess:

- Specific training and sufficient experience for the tasks.
- Knowledge of the technical standards and applicable laws.
- Knowledge of the national and local safety and installation standards.

Any work carried out on the electrical part of the pump should be authorized by the person responsible for safety.

Given that the pump is intended to form part of a system, it is the responsibility of whoever supervises the installation of the entire system to guarantee absolute safety, adopting the necessary measures of additional protection.

2.5. General safety information



Live parts

Possible consequence: fatal or very serious injuries.

- Risk mitigation: the device must be disconnected from the power supply before it is opened
- Isolate damaged, faulty or manipulated devices from the mains in order to de-energise.



Lack of emergency stop switch

Possible consequence: fatal or very serious injuries.

- An emergency stop switch must be connected for the entire system. This should enable the entire system to be shut down in the event of an emergency in such a way that the overall system can be brought into a safe condition.



Unauthorized access

Possible consequence: Fatal or very serious injuries.

- Risk mitigation: ensure that there can be no unauthorized access to the pump or to the system.



Hazardous media/contamination of persons and equipment

Possible consequences: Fatal / serious injuries, material damage.

- Ensure that the tubes are chemically resistant against the media

being handled.

- Always observe the safety data sheets for the media to be handled. The system operator must ensure that these safety data sheets are available and that kept up-to-date.
- The safety data sheets for the fluid being handled are always decisive for initiating countermeasures and/or first aid in the event of leakage of the fluid.
- Observe the general restrictions in relation to viscosity limits, chemical resistance and density.
- Always switch the pump off before exchanging the tube.

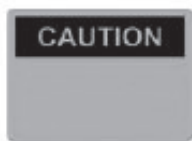

Incorrect and improper use

Possible consequence: fatal or very serious injuries.

- The unit is not intended to convey or regulate gases or solid media.
- Do not exceed the rated pressure, speed or temperature for the pump.
- Maximum pressure on suction/inlet side is 0,5 bar (7 psi approx.).
- The unit may only be used in accordance with the technical data and specifications provided in these operating instructions and in the operating instructions for the individual components.
- This pump is NOT supplied for use in areas of risk from explosion. ATEX versions of BOYSER pumps are available and they are supplied with a special ATEX version of the instruction manual.
- Only switch the pump on if it has been properly fastened to the floor.
- Only switch the pump on if the front cover has been attached.
- Do not carry out any maintenance operations or dismantle the pump without first making sure that the pipes are not under pressure and are empty or isolated.
- In the case of the tube becoming stuck during extraction or fitting it is necessary to reverse the direction of the pump, re-lubricate, and then repeat the operation.
- As the peristaltic pump is volumetric and its functioning is positive displacement, it is necessary to prevent a possible overload of pressure, due to, for example, the accidental closure of a valve. For this reason, it is advisable to fit a safety device such as: a safety valve, pressure limiter, etc.



Operational lifetime of the tubes

Possible consequence: fatal or very serious injuries.

- The tube has an indeterminate life and due to the possibility of its breakage or deterioration, the user is responsible for the preven-

tion of a possible (although most unlikely) incorporation of particles from the tube into the product being pumped. This can be achieved by means of filtration, a tube rupture alarm or other means suitable for the respective process



CIP cleaning

- In the event of CIP cleaning, it is necessary to obtain information from the manufacturer about correct installation of the pump (a special installation is required) as well as regarding the compatibility of the cleaning agents with the tubes and the hydraulic connections.
- Cleaning should be undertaken at the recommended maximum temperature.



Direction of rotation/flow direction

Possible consequence: material damage, destruction of the unit.

- The pump's direction of rotation in relation to the desired flow direction must be checked prior to every start.



Disconnect the pump from the mains

Possible consequence: personal injury.

- Work may only be carried out on the pump after it has previously been switched off and disconnected from the mains.



Environmental influences

Possible consequence: material damage up to destruction of the unit.

- The device is suitable for outdoor operation once it is covered and protected from rain and direct sunlight. Ambient conditions must also be respected, see Section 6.2 & 6.3.
- Take suitable measures to protect the device from environmental influences such as
 - UV rays
 - moisture
 - frost, etc.

3. Functional description

The DSM Series is a positive displacement pump. The feed chemical is conveyed by the rotor squeezing the tube in the direction of flow. No valves are needed for this. This ensures gentle handling of the metered media.

Maximum pressure on suction/inlet side is 0,5 bar (7 psi approx.).

The DSM Series has been designed for safe and uncomplicated operation, as well as straightforward maintenance.

The DSM Series can be used for many different media. However, this pump type is often the optimal solution for abrasive, shear-sensitive and viscous media.

Typical areas of use include processes where only a low discharge pressure is required (max. 2 bar).

3.1. Main modules:

1. Drive Unit
2. Housing
3. Base frame

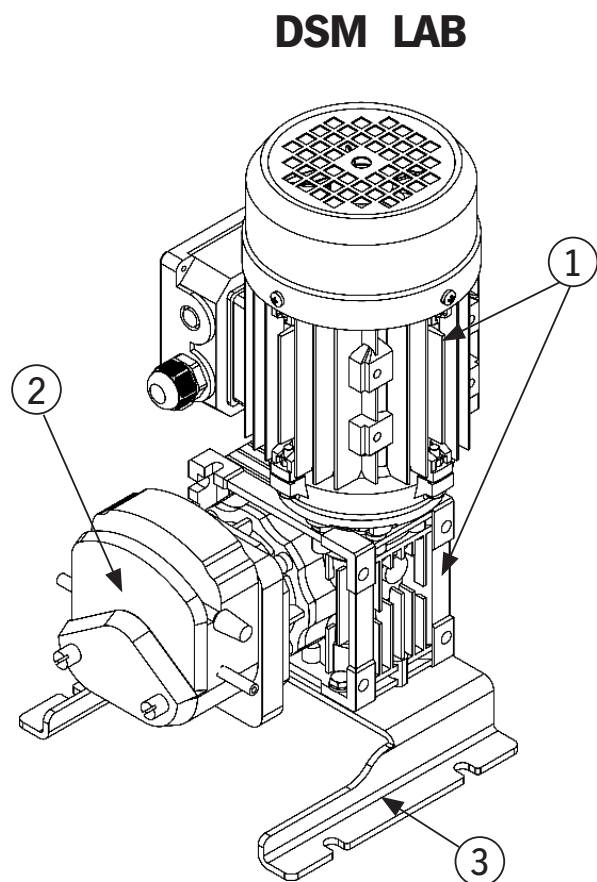
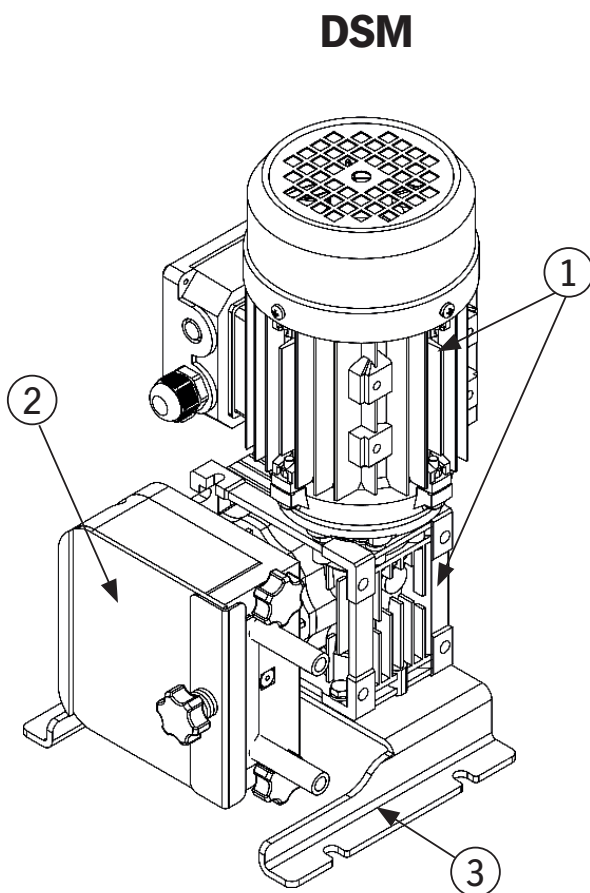

DESCRIPTION	UNIT	TUBE (Ø)	DSM	DSM/LAB
Max. capacity continuous	l/h	--	55,8	25,4
Max. capacity intermittent	l/h	--	84	38,2
Capacity per revolution	ml/rev	1,6 mm	0,4	--
	ml/rev	3,2 mm	1,65	0,75
	ml/rev	4,8 mm	3,80	1,72
	ml/rev	6,4 mm	5,61	2,54
	ml/rev	8,0 mm	10,00	4,55
Max. permissible working pressure	bar	--	2	2
Permissible ambient temperature	°C	--	-10 to +40	-10 to +40
Permissible product temperature	°C	--	-10 to +80	-10 to +60
Sound level at 1m	dB (A)	--	70	70

4. DESCRIPTION

4.1. Identification of the product

- A: Pump head
- B: Gearbox
- C: Electric motor

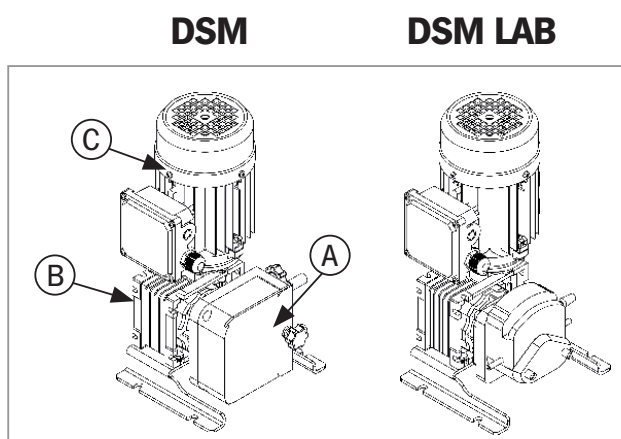

4.2. Identification of the pump

- MOD: Type number
- Nº: Serial number
- YEAR: Year of manufacture

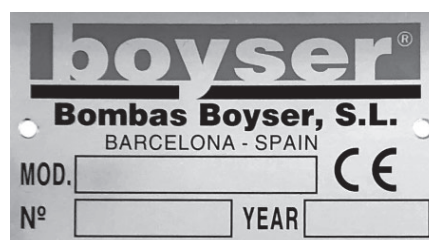

4.3. Identification of the gearbox (B)

The gearbox has an identity plate with the model, serial number and manufacturer's details as well as information relevant to its function such as reduction ratio.

4.4. Identification of the electric motor (C)

The motor has an identity plate with the model, serial number and manufacturer's details as well as information relevant to its' function such as electric power.

5. CONSTRUCTION

The pump housing is closed off with a bolted front cover in order to avoid the risk of injury. The motor serves to drive the rotor. Two shoes attached to the rotor serve to press the tube against the pump housing.

The rotary movement of the rotor alternately presses and releases the shoes against the tube. This serves to suck the media and convey it into the metering line.

5.1. Diagram of functional principle

1. Housing
2. Rotor
3. Tube

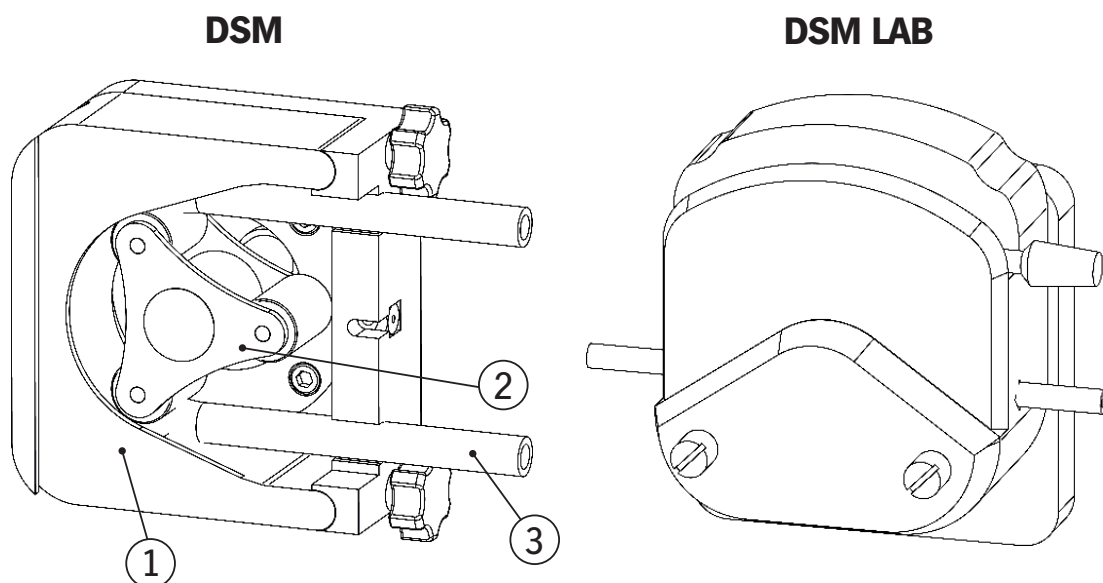

6. TRANSPORT AND STORAGE

6.1. Transport

- The pump is protected by cardboard packaging or a wooden crate.
- The packaging materials are recyclable.

6.2. Storage for less than 1 month

- The pump should be in a resting position, rotor in horizontal position.
- Avoid areas open to harsh weather or excessive humidity and temperatures lower than 0°C or higher than 30°C.
- Spare tubes should be stored in a dry place away from direct light.

6.3. Storage for more than 1 month

- Avoid areas open to harsh weather or excessive humidity and temperatures lower than 0°C or higher than 30°C.
- **IMPORTANT** Disassemble the tube from the housing (see section 8.2).
- For storage periods of longer than 30 days, protect the coupling surfaces (clamps, reducers, motors) with adequate anti-rust protection.
- For storage periods longer than 6 months, rotate the rotor a few turns to prevent damage to bearings and oil seals and to prevent grease migration.
- Spare tubes should be stored in a dry place away from direct light.

6.4. Elevation

- DSM pumps sizes can be lifted manually.
- It is the customer's responsibility to adhere to local workplace legislation.

Weights	DSM	DSM/LAB
Total pump weight	<11 kg	<11 kg
	<24,25 lbs	<24,25 lbs
Lifting	1 person	1 person

7. ASSEMBLY, COMMISSIONING AND INSTALLATION

7.1. Ambient conditions

Assembly is to be carried out in the following order.

If the pump has to be installed outdoors, then it is to be equipped with protection against sunlight and weather influences.

When positioning the pump, ensure that sufficient room for access is provided for all types of maintenance work.

Limit values for tube temperature and pressure.

Tube Material	Min. Temp. (°C) Feed chemical	Max. Temp (°C) Feed chemical	Min. Temp (°C) Environment	Max. Pressure (bar)
NORPRENE	- 10	90*	- 10	2
SILICONE	- 10	90*	- 10	2
SOLVA	- 10	70	- 10	2

* At max. temperature, the life of tube is drastically reduced.

Please contact BOYSER for applications with feed chemical temperature higher than 60°.

7.2. Commissioning

7.2.1. Testing prior to commissioning the pump

The following tests are to be carried out:

- Only switch the pump on if the front cover has been properly attached.
- Check that the mains voltage is suitable for the motor.
- Check that the thermal overload protection (not included in the delivery scope) corresponds to the value specified on the motor type plate.
- Confirm that pump has been properly earthed.
- Connect the electric motor according to local applicable rules and regulations. The electrical installation work must be carried out by qualified personnel.
- Check that the optional electrical components are connected and are working properly.
- Check whether the direction of rotation is correctly adjusted.

7.3. Correct installation of the pump

- Ensure that the pump has not been damaged during transportation or storage. Immediately report any damage to the supplier.

- Ensure that all the packaging has been removed.
- Check that the information printed on the identification plate corresponds with the order.
- Check the operating instructions in order to ensure that the flow values, pressures & power consumption of the motor do not exceed rated values.
- Ensure that the tube is suitable for the fluid to be conveyed and that it is not damaged.
- Make sure that the temperature of the liquid does not exceed the recommended temperature range.
- Ensure that there is enough space for free airflow around the motor.
- Ensure that no nearby objects or direct sunshine radiate additional heat to the motor.

7.3.1. Suction side

- Install a manometer in the pressure line if the back-pressure value is unknown. Maximum pressure on suction/inlet side is 0,5 bar (7,25 psi approx.).
- The pump is to be positioned as near as possible to the liquid container, so that the suction side is kept as short and straight as possible.
- The suction line must be absolutely airtight and made of a suitable material, so that it does not collapse under vacuum.
- The diameter must correspond to the rated diameter of the tube. A larger diameter is recommended in the event of viscous liquids.
- The pump is self-priming and does not require an admission valve.
- The pump is reversible and the suction side can be connected to either hydraulic connection of the pump. Normally, the option is selected which is best suited to the physical conditions of the rest of the installation.

7.3.2. Discharge side

- The discharge line is to be kept as straight and short as possible, in order to avoid performance reduction.
- The diameter must correspond to the rated diameter of the tube. A larger diameter is recommended in the event of viscous liquids.
- Do not close or block the outlet since, as it is a volumetric pump, it would cause the tube to break or an electro-mechanical overload.

8. Torque values

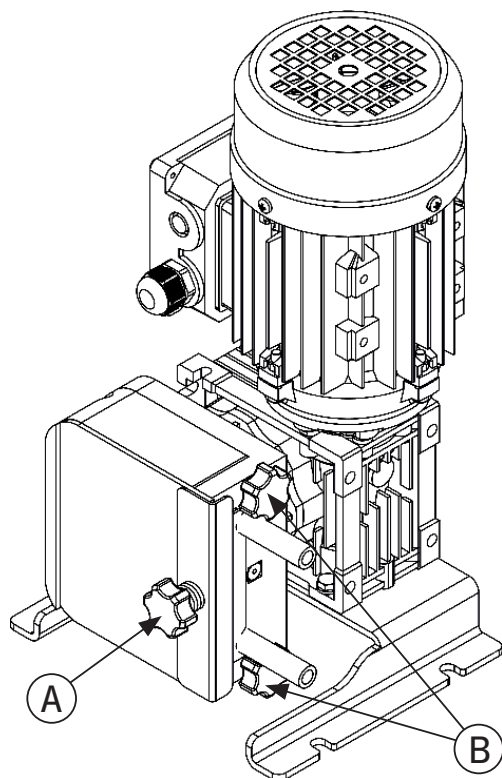

	Description	Units	DSM- DSM/LAB
A	Cover bolts	-	Manual, no bolts
B	Cover bolts	-	Manual, no bolts

8.1. Lubrication

DSM pumps only require a thin film of grease to reduce the friction between the roller and the outer surface of the tube. No other lubrication is necessary.

Lubricant quantity table

Type	Unit	DSM-DSM/LAB
Lubricant	-	BOYSER
Silicone grease quantity	gramme	10-20
	ounce	0,35 – 0,71

8.1.1. Changing oil in gearbox

The instructions manual of the gearbox are usually delivered with the IOM of the Boyser pump.

Some models of gearbox are lubricated for life, other models of gear reducers require regular maintenance according to the instructions manual of the gear reducer manufacturer.

In case of doubt, please contact the gearbox manufacturer or their authorised distributor in your country.

8.2. Exchanging the DSM tube

1. Close off all valves, in order to prevent leakage of the feed chemical.
2. Dismantle the pipes from both discharge and suction sides.

3. Remove the front cover. Front covers of DSM Series can be removed manually.



4. Insert an allen key into bolt on the left of the housing to stop the bolt from rotating and twist off the star knob on the right.



5. Slide off the removable housing.

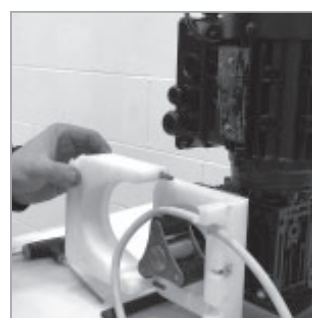

6. Clean removable housing and rollers.



7. Apply lubricant to the rollers and the removable housing with a small brush.



8. Place new tube around the roller and through the slots in the housing.



9. Place the allen screws in the removable housing and slide it on the housing.



10. Use the allen key to stop the bolt from rotating and twist the star knob until both parts of the housing are in contact.



11. Install the front cover.



12. Begin to twist the star knob.

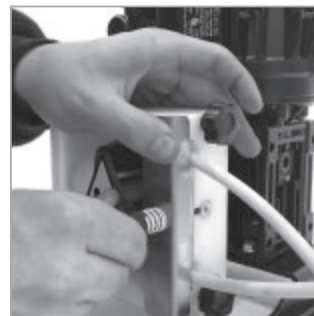

13. With one hand pull on the tube without stretching it and with the other hand continue to twist the star knob until the front cover is closed.



14. The tube changing process is complete. To check that the tube is correctly held in place, pull on one end to make sure that no movement is possible.



15. Mount the pipes from both discharge and suction sides.
16. Open all of the valves.

8.3. Exchanging the DSM-LAB tube

1. Close off all valves, in order to prevent leakage of the feed chemical.
2. Dismantle the pipes from both discharge and suction sides. Lift the lever.



3. Remove tube.

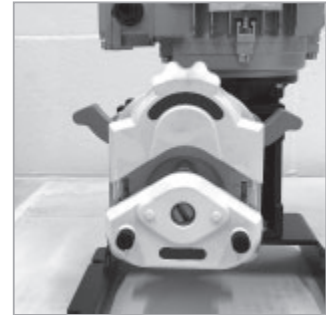

4. Position the new tube.

5. Lower the lever.

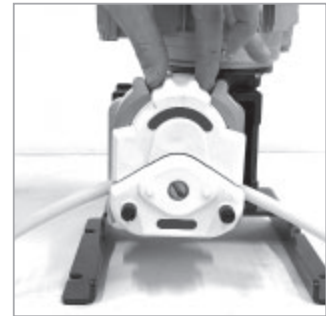

6. Mount the pipes from both discharge and suction sides.

7. Open all of the valves.

8.4. Replacement of electric motor

For repair or replacement of the electric motor they could be disassembled from the pump housing. The pump is stable on its baseplate and will not fall over when the electric motor is disassembled.

No support set is necessary.

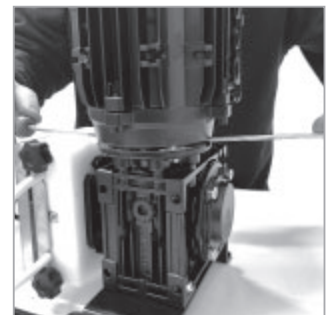
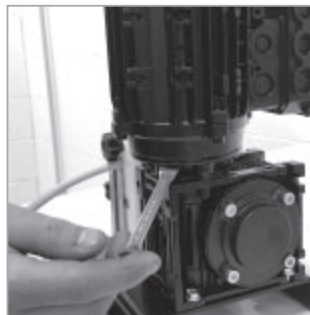

8.5. Addition of leak detection sensor

Standard DSM pump housing is not prepared for addition of leak detection sensor.

The alternative is to order the DSM pump assembled onto a collector with its own leakage detector



DSM SERIES

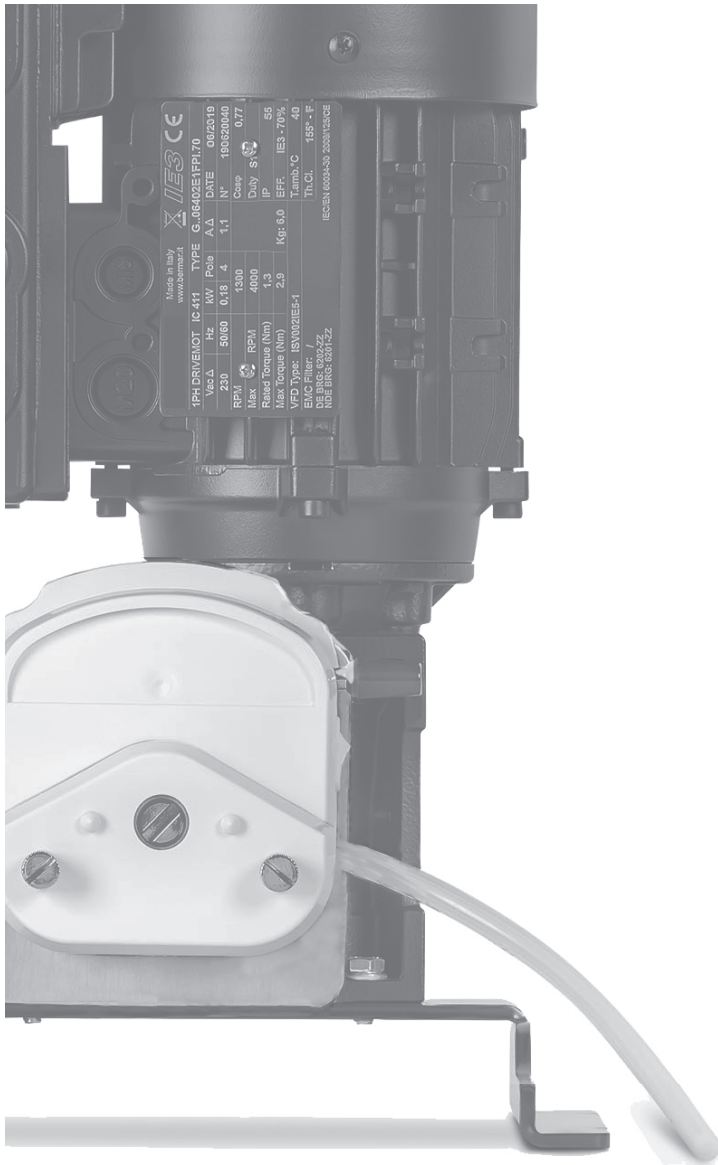

9. Troubleshooting

Problem	Possible cause	Solution
Increased pump temperature	Tube has no lubricant	Lubricate tube
	Increased product temperature	Reduce product temperature
	Insufficient or poor suction conditions	Check suction line condition
	Pump speed too high	Reduce pump speed
Reduced flow or pressure	Valves on discharge and or suction side completely or partially closed	Open valves
	Tube insufficiently compressed	Check number of shims
	Tube rupture (the product leaks out into the housing)	Exchange tube and clean pump
	Partial blockage of the suction line	Clean pipe
	Insufficient product quantity in storage container	Fill storage container or exchange pump
	Insufficient diameter on the suction side	Increase the diameter on the suction side, as far as possible
	Suction line too long	Shorten the suction line, as far as possible
	High viscosity of medium	Reduce viscosity, as far as possible
	Air introduction in the suction connections	Check connections and accessories for air tightness
	High pulsation on suction	Tighten connections and accessories Mount anti-pulsation equipment Reconsider application (speed, etc.)
Vibrations on pumps and pipelines	The pipes are not correctly fastened	Fasten pipes correctly (e.g. wall brackets)
	Pump speed too high	Reduce pump speed
	Insufficient nominal width of the pipes	Increase nominal width
	Pump base plate loose	Fasten base plate
	Pulsation dDSMers insufficient or missing	Install pulsation dDSMers on suction and / or discharge side

Short operational lifetime of the tubes	Chemical exposure	Check the compatibility of the tube with the liquid being conveyed, the cleaning fluid and the lubricant
	High pump speed	Reduce pump speed
	High conveying temperature	Reduce product temperature
	High operating pressure	Reduce operating pressure
	Pump cavitation	Check the suction conditions
	Abnormal elevation of temperature	Check number of shims
	Unsuitable lubricant	Use Boyser lubricant
	Insufficient quantity of lubricant	Reapply lubricant
Tube pulled into the pump housing	High inlet pressure (>0,5 bar)	Reduce inlet pressure
	Tube filled with deposits	Clean or replace the tube
	Holder (press flange) insufficiently tightened	Re-tighten holder (press flange)
	Insufficient lubricant	Reapply lubricant
The pump does not start up	Insufficient motor performance	Check motor and replace if necessary
	Insufficient output from frequency converter	The frequency converter must match the motor
	Blockage in the pump	Check voltage. Start occurs at minimum 10 Hz
	Blockage in the pump	Check if the suction or discharge side is blocked. Rectify blockage

10. Spare parts exploded view DSM model

10.1. Spare parts DSM-10 model

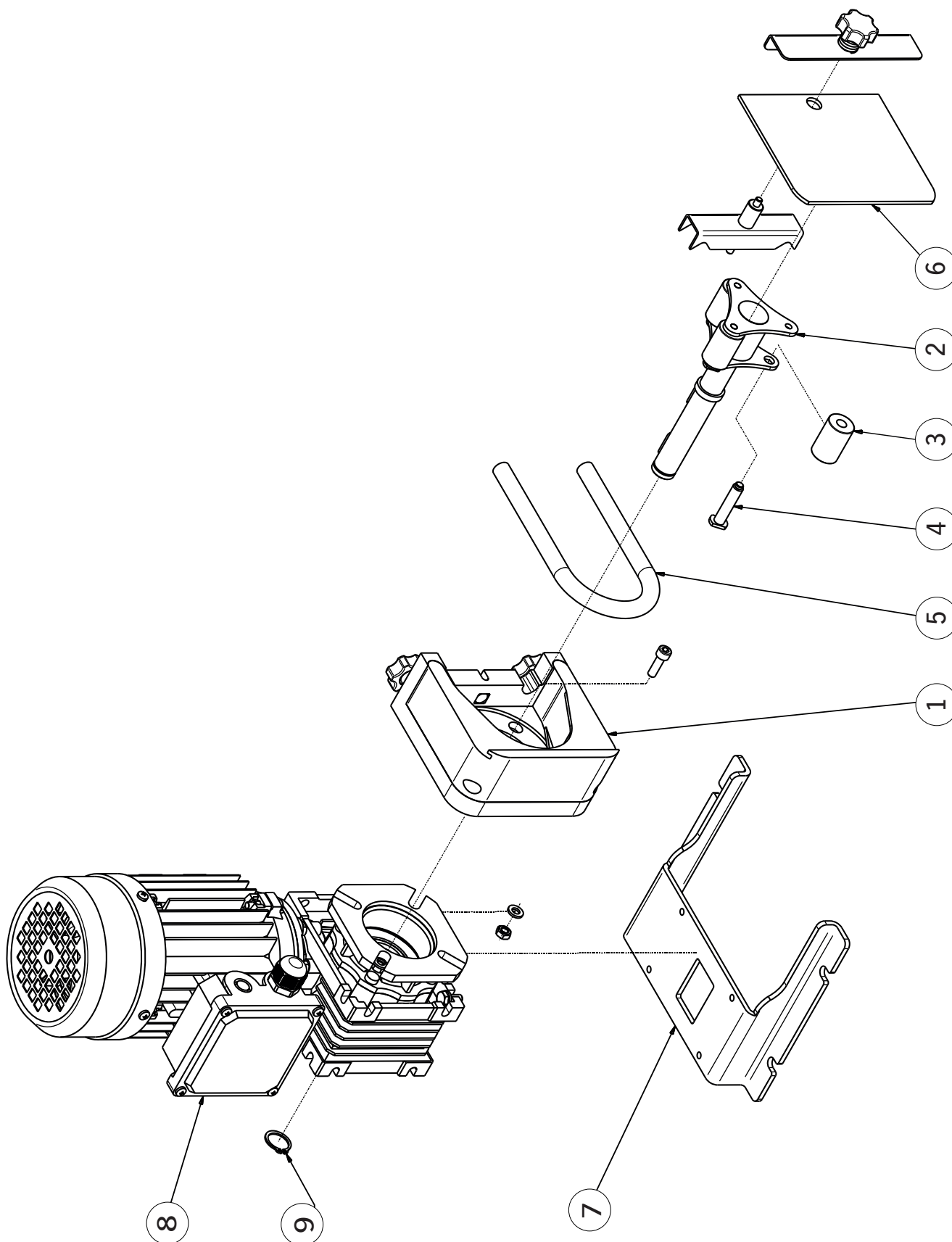

Pos.	Description	Qty	Reference
1	Pump Housing ATEX DS-M (BLACK)	1	
1	Pump Housing DS-M	1	
2	Rotor DS-M	1	115.00.04
3	Roller DA Tubo 1,6 mm DS-M	3	115.00.07
3	Roller DA Tubo 2,4 mm DS-M	3	115.00.05
4	Roller shaft	3	115.00.09
5	Peristaltic Hose ØId.1,6x2,4mm SILICONES DSM	1	SIL-16.24.05
5	Peristaltic Hose ØId.3,2x2,4mm SILICONES DSM	1	SIL-32.24.05
5	Peristaltic Hose ØId.4,8x2,4mm SILICONES DSM	1	SIL-48.24.05
5	Peristaltic Hose ØId.6,4x2,4mm SILICONES DSM	1	SIL-64.24.05
5	Peristaltic Hose ØId.8,0x2,4mm SILICONES DSM	1	SIL-80.24.05
5	Peristaltic Hose ØId.4,8x2,4mm NORPRENE G DSM	1	NORG-48.24.05
5	Peristaltic Hose ØId.6,4x2,4mm NORPRENE G DSM	1	NORG-64.24.05
5	Peristaltic Hose ØId.8,0x2,4mm NORPRENE G DSM	1	NORG-80.24.05
5	Peristaltic Hose ØId.1,6x2,4mm NORPRENE F DSM	1	NORF-16.24.05
5	Peristaltic Hose ØId.3,2x2,4mm NORPRENE F DSM	1	NORF-32.24.05
5	Peristaltic Hose ØId.4,8x2,4mm NORPRENE F DSM	1	NORF-48.24.05
5	Peristaltic Hose ØId.6,4x2,4mm NORPRENE F DSM	1	NORF-64.24.05
5	Peristaltic Hose ØId.8,0x2,4mm NORPRENE F DSM	1	NORF-80.24.05
5	Peristaltic Hose ØId.3,2x2,4mm SOLVA DSM	1	SOL-32.24.05
5	Peristaltic Hose ØId.4,8x2,4mm SOLVA DSM	1	SOL-48.24.05
5	Peristaltic Hose ØId.6,4x2,4mm SOLVA DSM	1	SOL-64.24.05
5	Peristaltic Hose ØId.8,0x2,4mm SOLVA DSM	1	SOL-80.24.05
6	Polycarbonato Cover DS-M	1	115.00.16
7	Base plate DS-M	1	115.00.14
7	Base plate Stainless Steel DS-M	1	115.00.15
8	Drive	1	
9	Segger ring shaft DS-M DIN471 - Ø18 mm	1	115.00.10

Norprene G for Industrial use only. Norprene F for Food-Grade applications

10.2. Spare parts exploded view DSM/LAB model

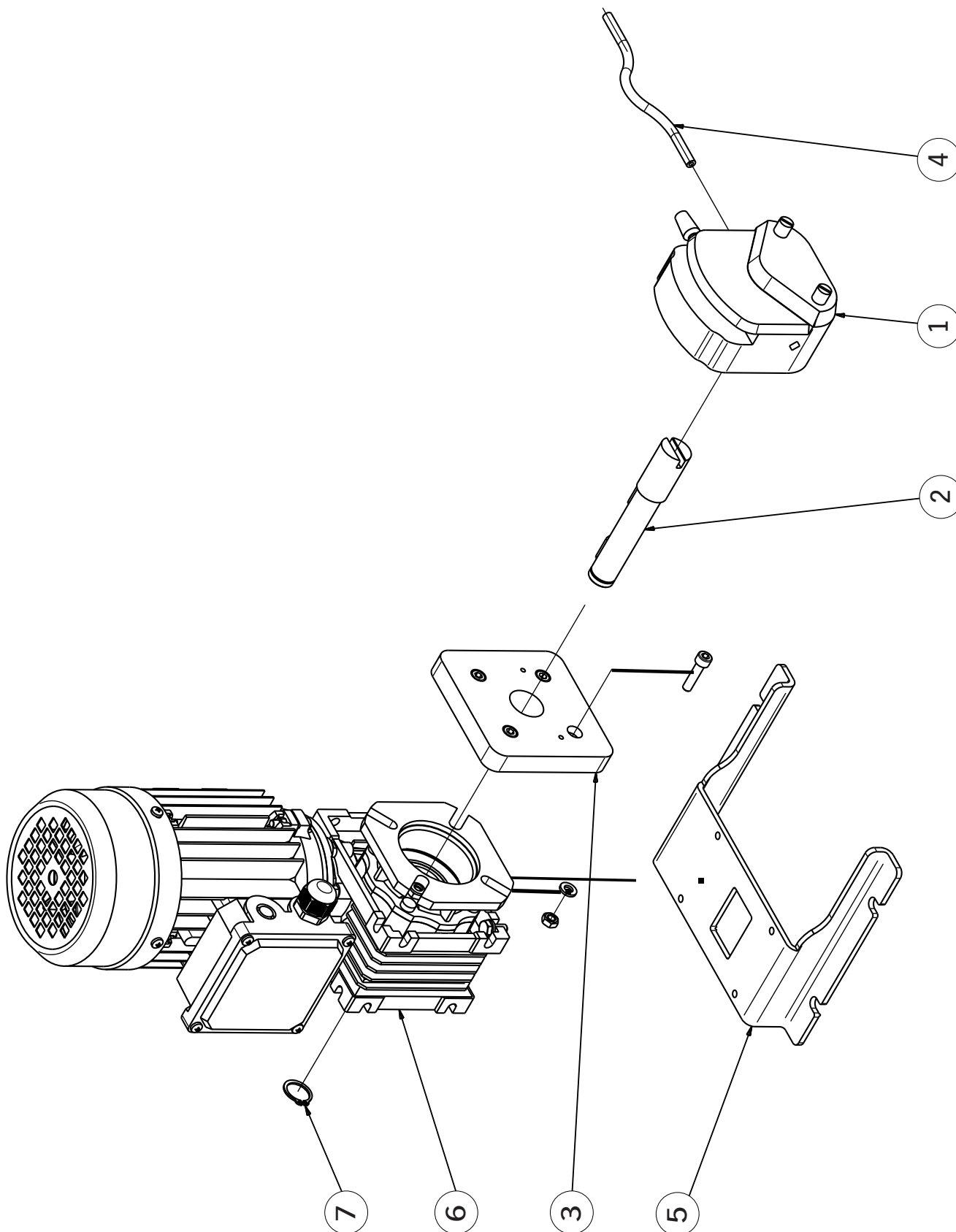

Pos.	Description	Qty	Reference
1	Laboratory Pump	1	115.00.75
2	Shaft DS-M LAB	1	115.00.77
3	Intermediate Plate DS-M LAB	1	115.00.76
4	Peristaltic Hose Øld. 1,6x2,4mm SILICONE DS-M LAB	1	SIL-16.24.05
4	Peristaltic Hose Øld. 3,2x2,4mm SILICONE DS-M LAB	1	SIL-32.24.05
4	Peristaltic Hose Øld. 4,8x2,4mm SILICONE DS-M LAB	1	SIL-48.24.05
4	Peristaltic Hose Øld. 6,4x2,4mm SILICONE DS-M LAB	1	SIL-64.24.05
4	Peristaltic Hose Øld. 8,0x2,4mm SILICONE DS-M LAB	1	SIL-80.24.05
4	Peristaltic Hose Øld. 4,8x2,4mm NORPRENE G DS-M LAB	1	NORG-48.24.05
4	Peristaltic Hose Øld. 6,4x2,4mm NORPRENE G DS-M LAB	1	NORG-64.24.05
4	Peristaltic Hose Øld. 8,0x2,4mm NORPRENE G DS-M LAB	1	NORG-80.24.05
4	Peristaltic Hose Øld. 1,6x2,4mm NORPRENE F DS-M LAB	1	NORF-16.24.05
4	Peristaltic Hose Øld. 3,2x2,4mm NORPRENE F DS-M LAB	1	NORF-32.24.05
4	Peristaltic Hose Øld. 4,8x2,4mm NORPRENE F DS-M LAB	1	NORF-48.24.05
4	Peristaltic Hose Øld. 6,4x2,4mm NORPRENE F DS-M LAB	1	NORF-64.24.05
4	Peristaltic Hose Øld. 8,0x2,4mm NORPRENE F DS-M LAB	1	NORF-80.24.05
4	Peristaltic Hose Øld. 3,2x2,4mm SOLVA DS-M LAB	1	SOL-32.24.05
4	Peristaltic Hose Øld. 4,8x2,4mm SOLVA DS-M LAB	1	SOL-48.24.05
4	Peristaltic Hose Øld. 6,4x2,4mm SOLVA DS-M LAB	1	SOL-64.24.05
4	Peristaltic Hose Øld. 8,0x2,4mm SOLVA DS-M LAB	1	SOL-80.24.05
5	Base plate DS-M	1	115.00.14
5	Base plate Stainless Steel DS-M	1	115.00.15
6	Drive	1	
7	Segger ring shaft DS-M DIN471 - Ø18 mm	1	115.00.10

Norprene G for Industrial use only. Norprene F for Food-Grade applications

11. End-of-Life



WARNING! Danger from hazardous substances!

Possible consequence: Fatal or very serious injuries.

Customer must decontaminate the pump with suitable agents (refer to the material safety data sheet for the fluid).

11.1. Recycling

Once cleaned the following components can be scrapped/recycled:

- Pump housing
- Rotor and rollers
- Baseplate
- Drive

Some specialist disassembly may be required.

11.2. Recycling-Repurposing

The following components even when cleaned must still be prepared for special waste disposal.

Customer is responsible to follow local legislation for reuse or environmentally friendly processing of packaging materials, (contaminated) lubricant, oil and the following components.

- Tube
- Plastic

Once the tube has been cleaned it may be disposed of using the same methods as car tyre disposal **follow local regulations**.



EC DECLARATION OF CONFORMITY

BOMBAS BOYSER, S.L.

C/.Miquel Martí i Pol, s/n Pol. Ind.Pla de la Costa - 08182 Sant Feliu de Codines - (Barcelona) Spain
Company responsible for manufacturing and commercializing the below specified machine:

DS-M SERIES PERISTALTIC PUMP

Declare under our sole responsibility:

Its conformity in accordance with all applicable provisions of the Machinery Directive (2006/42/EC), Low Voltage Directive (2014/35/EU), Electromagnetic Compatibility and Repealing Directive (2014/30/EU), national applicable regulations, and with the provisions of the following standards applied:

<u>Reference Standard</u>	<u>Title of the harmonized standard</u>	<u>Publication date</u>
EN-ISO-12100	Safety of machinery - General principles for design - Risk assessment and risk reduction.	2012
EN-614-1	Safety of machinery – Ergonomic design principles- Part 1: Terminology and general principles.	2006+A1/2009
EN- ISO-14120	Safety of machinery-Guards- General requirements for the design and construction of fixed and movable guards.	2016
EN-60204-1	Safety of machinery-Electrical equipment of machines- Part 1: General requirements.	2007/A1:2009
EN-60335-1	Household and similar electrical appliances - Safety - Part 1: General requirements	2012/A11:2014
EN-60034-1	Rotating electrical machines - Part 1: Rating and performance	2010/AC:2010
EN-809	Pumps and pump units for liquids - Common safety requirements.	1999+A1/2010
EN-ISO-14847	Rotary positive displacement pumps- Technical requirements.	1999

This declaration refers only to machines in the state of the market, with exclusion of the elements added and / or operations carried out subsequently by the end user.

The pump should not be put into service until the final machinery into which it is to be incorporated has been declared in conformity with the provisions of Directive 2006/42/EC.

Juan Jofresa
 Managing Director
 Bombas Boyser



www.boyser.com