

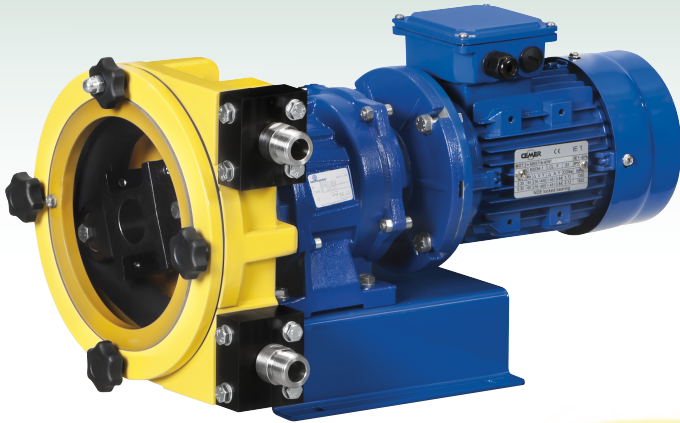

Industrial Peristaltic Pumps

AMP-16D Data sheet



Capacity:	0,092 l/rev.
Connections:	3/4"
Max. Pressure:	8 bar
Rotor system:	Rollers
Available hoses:	NR NBR EPDM HYPALON NR-A NBR-A
Available tubes:	TPV

Performance table

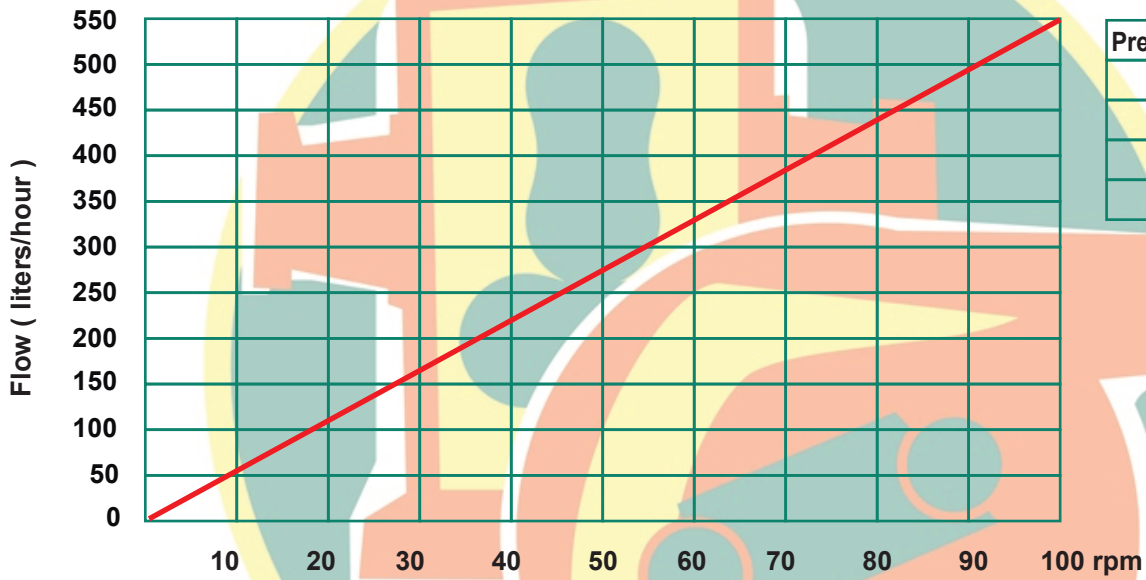

Pressure (bar)	Torque (Nm)
1	20
4	26
6	33
8	38

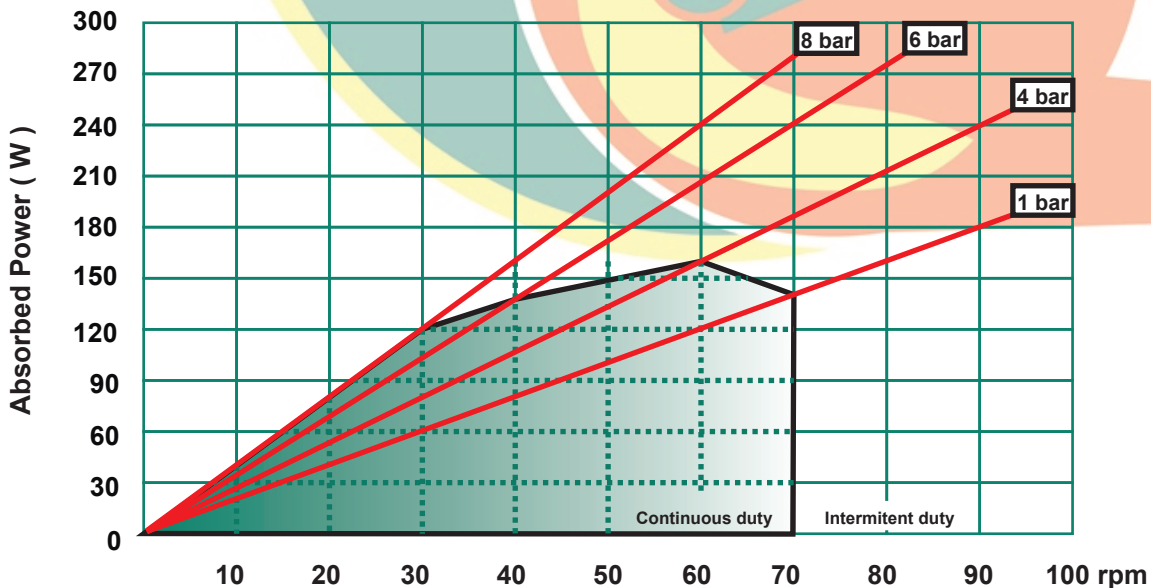

Description	Material	Surface treatment
Pump housing	Aluminium EN-AC-44100	Polyester powder coated Halar coated (Optional)
Front cover	Steel F-111 / Polycarbonate	Polyester powder coated Halar coated (Optional)
Rotor	Nodular Cast Iron EN-GJL-400	Cataphoresis
Rollers	Steel F-114	Blueing
Base plate	Steel F-111 Stainless Steel AISI-304 (Optional)	Polyester powder coated --
Connections	Stainless Steel AISI-304 Polypropylene (Optional) PVDF (Optional)	--

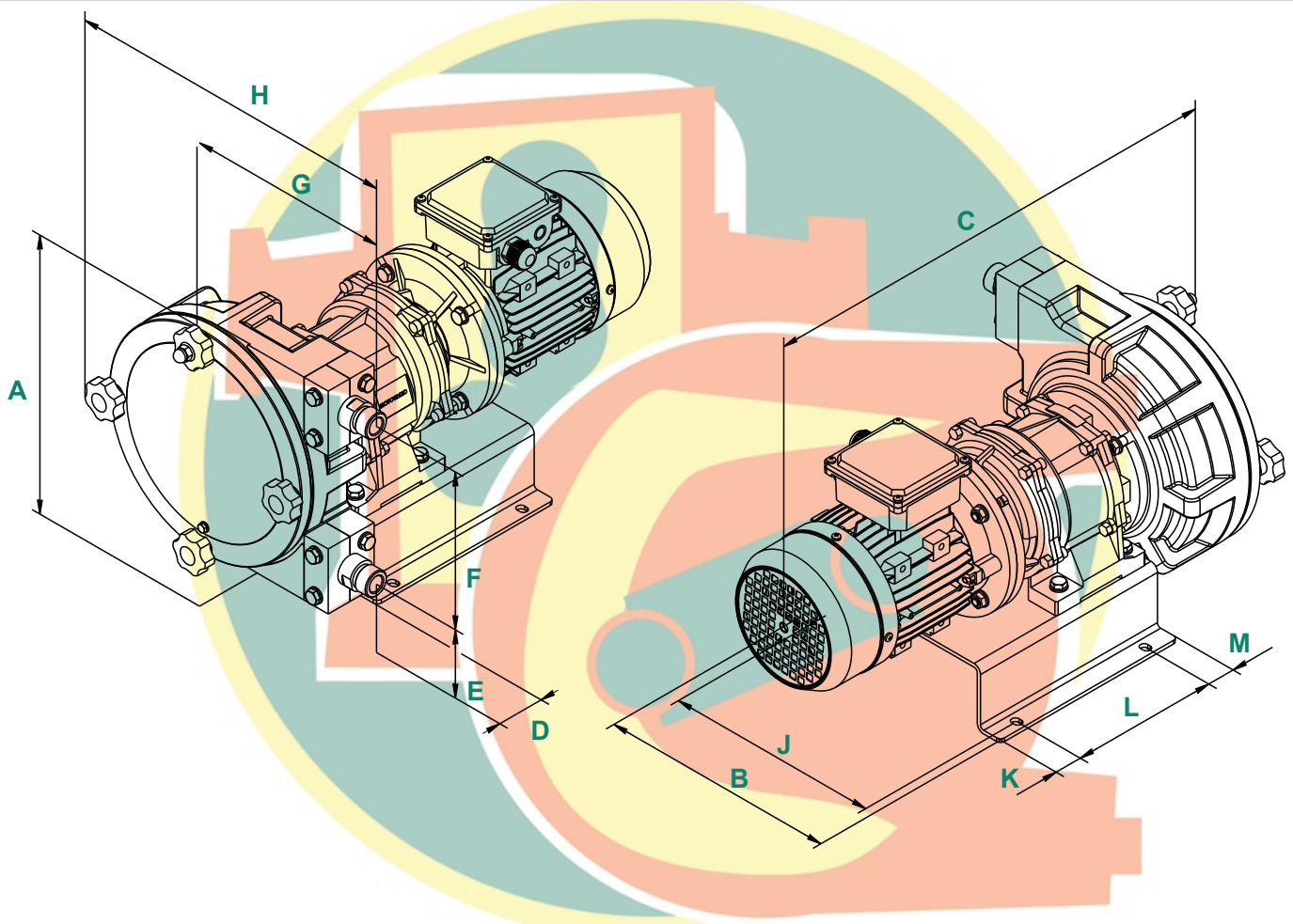

A	B	C	D	E	F	G	H	J	K	L	M	Connections
275	210	*	49	60	170	173	303	190	30	160	30	3/4" BSP

* To confirm according type and power driver.



Bombas Boyser, S.L.
c/ Miquel Martí i Pol, s/n Pol. Ind. Pla de la Costa
08182 Sant Feliu de Codines - Barcelona - Spain
Tel. +34 93 844 77 78 info@boyser.com
www.boyser.com

